

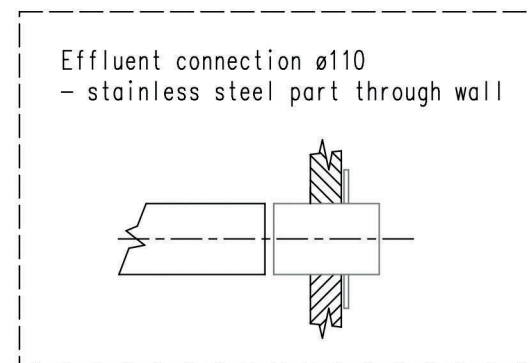

Connection hoses and cables	
Water hose:	✓
Waste water hose:	✗
Electric cable:	✓ 2x

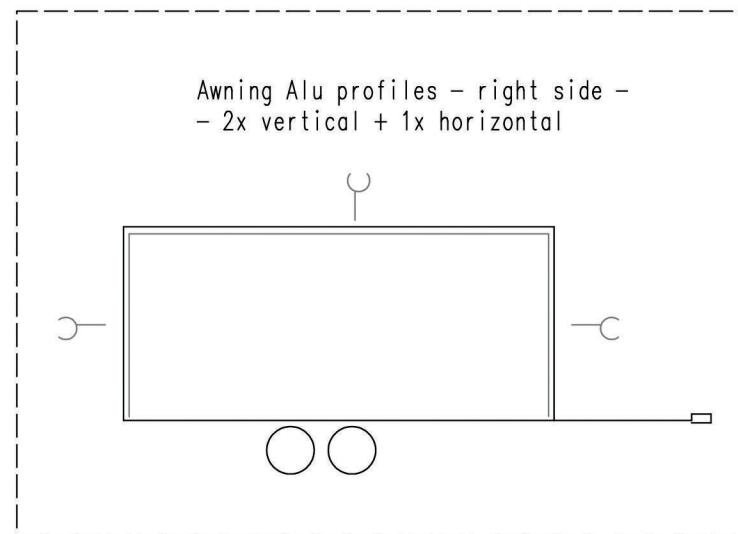
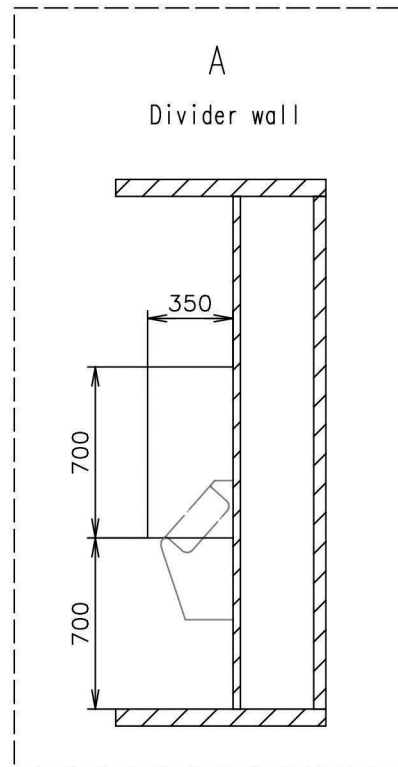
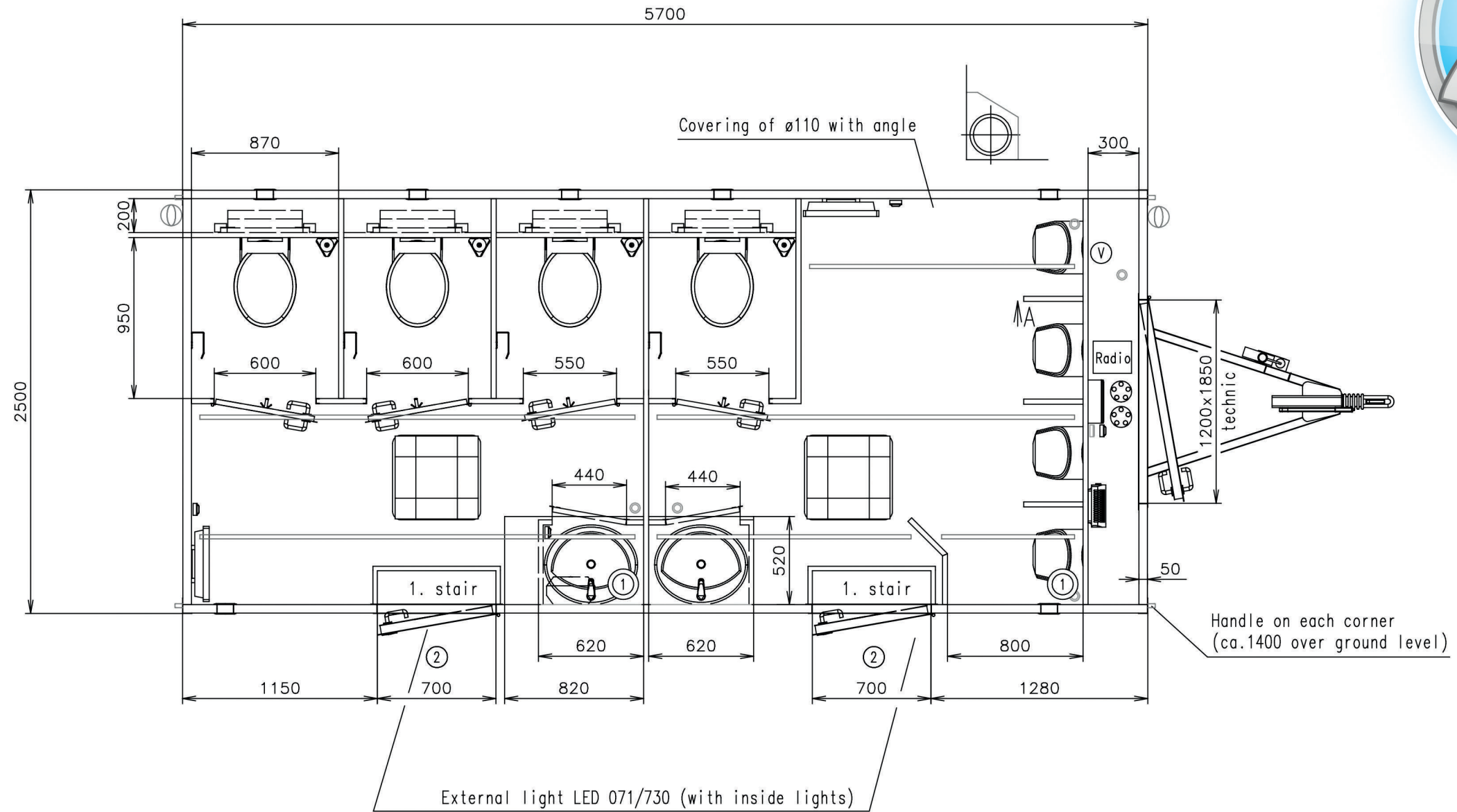

Working desks in waterproof compact desk Egger (dark color)

Interior doors + divider walls in black decor 6515

Notes: External doors - without cylinders Spare wheel - free loaded

Interior height:	2100 mm	Total weight:	2000 kg
Color:	RAL 7042	Tare weight-estimate:	1800 kg
Floor:	PVC Jupiter 148708	Centre of wheels from rear side:	2790 mm
Date:	30.11.2016	Wheels:	155 R13



TOILETTENWAGENVERLEIH
Thomas Sprenger

Drawing number:
2285-57-2_1/2 (Sprenger)

(Cabling and piping is not shown on the 3D views and drawings)

Connection hoses and cables	
Water hose:	✓
Waste water hose:	✗
Electric cable:	✓ 2x



- Ⓥ Water connection 3/4" (on the chassis) + filter + reduction valve
- Ⓜ 2x Electric connection (through the floor) (230V-16A) (1x heatings) (1x the rest)
- Ⓞ 2x Effluent connection ø110 (through wall) - stainless steel part
- Ⓟ Power point
- Ⓠ Light switch
- Ⓡ Switch board (1200 over floor)
- Ⓢ Light LED stripe
- Ⓣ Heating (500W)
- Ⓤ Heating (750W)
- Ⓥ Floor drain hole
- Ⓦ Ventilation ø120
- Ⓧ Wash-basin (built-in) Multi 1690 (550x470) + standard water tap
- Ⓨ Hanging toilet (toilet seat - steel holders)
- Ⓩ Urinal - Vitra Siko (water flush)
- ⓐ Hot water boiler Wterm FHN (5l)
- ⓑ Roof window Dometic (400x400)
- ⓒ Brush toilet
- ⓓ Toilet paper holder
- ⓔ Clothes hanger
- ⓕ Mirror (600x600) + black frame around
- ① Speaker
- ② Foldable stairs Fiona (update on fixing of stair) + stainless steel handrail

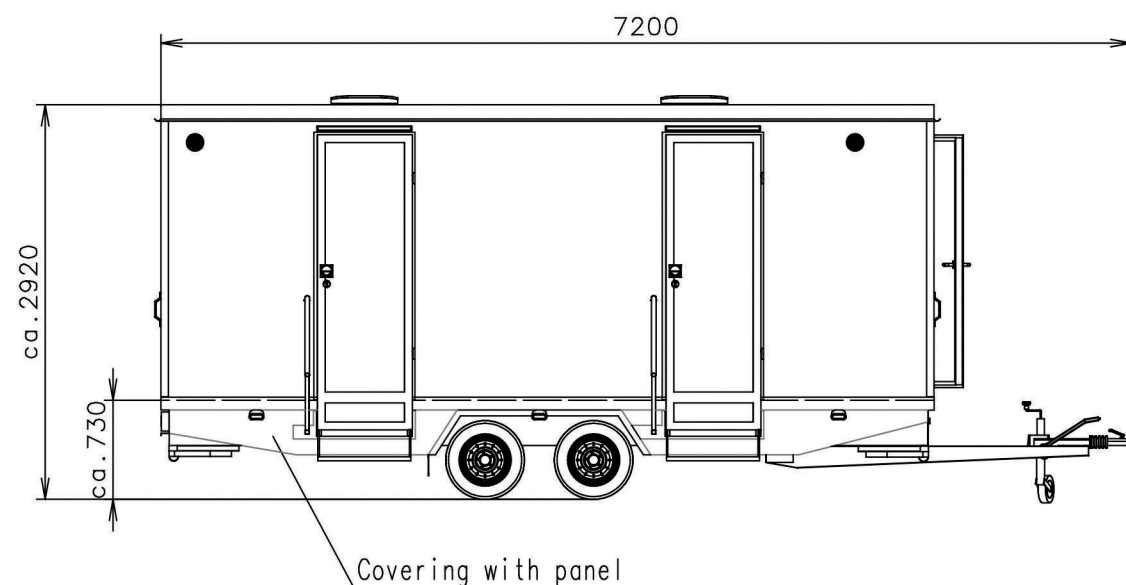

(Cabling and piping is not shown on the 3D views and drawings)

Working desks in waterproof compact desk Egger (dark color)

Interior doors + divider walls in black decor 6515

Notes: External doors - without cylinders Spare wheel - free loaded

Interior height:	2100 mm	Total weight:	2000 kg
Color:	RAL 7042	Tare weight-estimate:	1800 kg
Floor:	PVC Jupiter 148708	Centre of wheels from rear side:	2790 mm
Date:	30.11.2016	Wheels:	155 R13



Drawing number:
2285-57-2_2/2 (Sprenger)